

# KINGSMITH WalkingPad Treadmill

## MX10

## User Manual

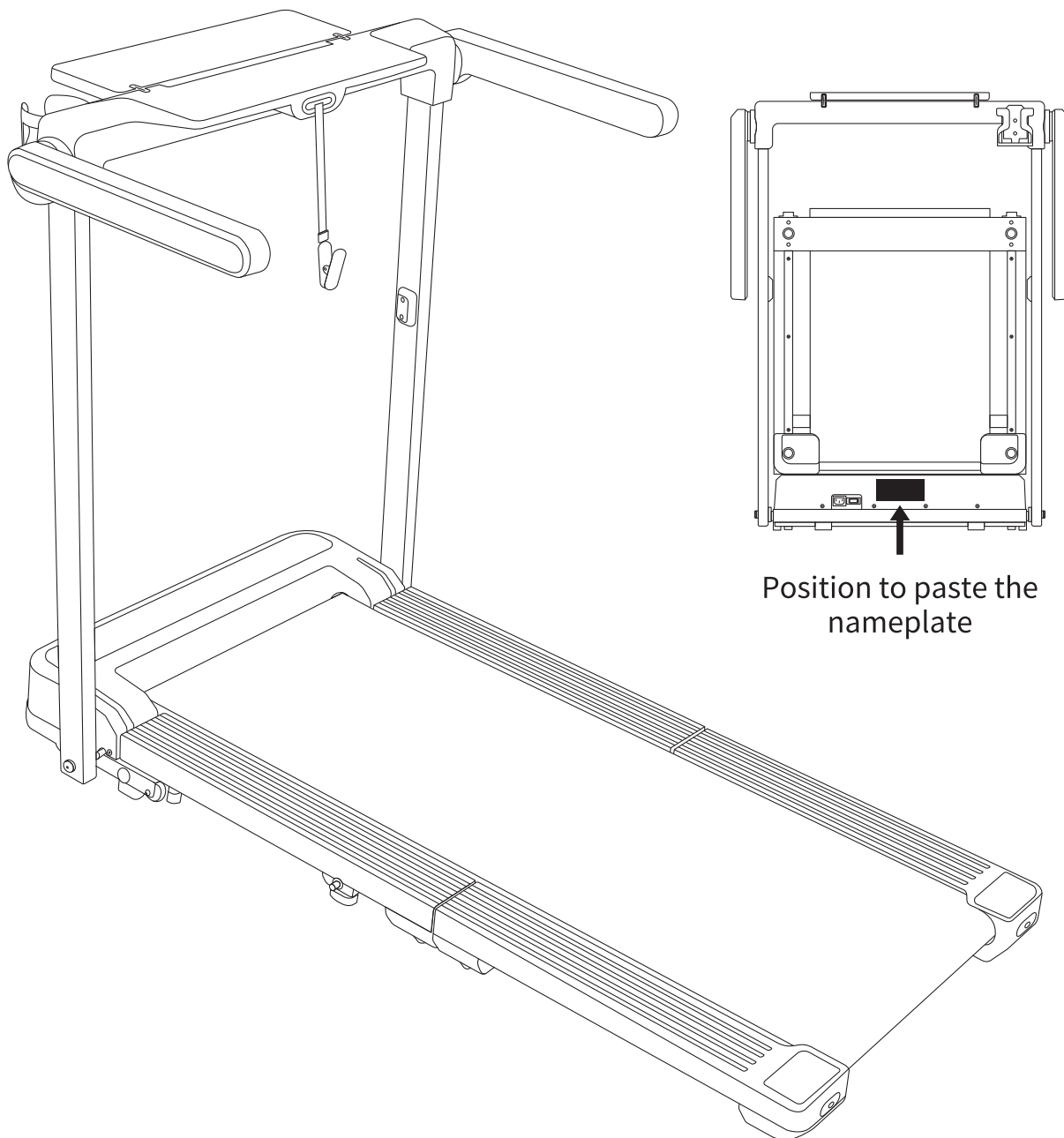

### WARNING

Please be careful to avoid slipping and injury when using.  
Do not let children approach or use this equipment.  
The product has an innovative folding design. Mind your hands and fingers when folding/unfolding it.  
Please read the user manual carefully before using the product. Save these instructions and retain for future reference.



Scan for more languages



Scan to download our app

# Safety Precautions

---

Thank you for choosing our KINGSMITH WalkingPad Treadmill (hereinafter referred to as "the equipment", "the product", etc). To ensure that you fully understand and use this product correctly, please read the following instructions carefully before use.

The equipment is intended for residential use.

## **DANGER** - TO REDUCE THE RISK OF ELECTRICAL SHOCK:

Always unplug the equipment from the electrical outlet immediately after using and before cleaning.

**WARNING** - This equipment can be used by children aged from 8 years and above and persons with reduced physical, sensory or mental capabilities or lack of experience and knowledge if they have been given supervision or instruction concerning use of the equipment in a safe way and understand the hazards involved. Children shall not play with the equipment. Cleaning and user maintenance shall not be made by children without supervision.

**WARNING** - This equipment is not intended for use by persons (including children) with reduced physical, sensory or mental capabilities, or lack of experience and knowledge, unless they have been given supervision or instruction concerning use of the equipment by a person responsible for their safety. Children should be supervised to ensure that they do not play with the equipment.

**WARNING** - Store the equipment vertically. Keep young children away from this machine at all times. Contact with the moving surface may result in severe friction burns.

## **WARNING** - TO REDUCE THE RISK OF BURNS, FIRE, ELECTRIC SHOCK, OR INJURY TO PERSONS:

- (1) Equipment should never be left unattended when plugged in. Unplug from outlet when not in use, and before putting on or taking off parts.
- (2) Do not operate under or near a blanket or pillow. Excessive heat can occur and cause fire, electric shock, or injury to persons.
- (3) The equipment is only to be used by healthy and able-bodied adults. Close supervision is necessary when this equipment is used by, on, or near children, invalids, or disabled persons.
- (4) The equipment is intended for consumer and residential use only. Do not use it in a commercial or light-commercial setting or outdoors or for medical treatment purpose.
- (5) Never operate this equipment if it has a damaged cord or plug, if it is not working properly, if it has been dropped or damaged, or dropped into water. Contact customer service for examination and repair. Do not use attachments not recommended by the manufacturer.
- (6) Do not carry this equipment by the supply cord or use the cord as a handle.
- (7) Keep the cord away from heated sources.
- (8) Never drop or insert any object into any opening.
- (9) Connect this equipment to a properly grounded outlet only.
- (10) Do not operate where aerosol (spray) products are being used or where oxygen is being administered.
- (11) To disconnect, turn all controls to the off position, then remove the plug from the outlet.
- (12) If you feel uncomfortable, please stop exercising immediately and consult a doctor to avoid damage to your health.
- (13) Ensure there is a distance of at least 2000 mm × 1000 mm behind the equipment and a distance of at least 600 mm on both sides.
- (14) Wear appropriate athletic clothing to use the equipment and exercise according to your own condition. Do not exercise barefoot or in socks only.
- (15) Do not wear loose or dangling clothing while using the product.
- (16) Do not stand or step on the head of the equipment.
- (17) Do not use this equipment with, near or around pets.
- (18) Do not walk backward on the equipment to ensure stability.
- (19) The elderly, children, and pregnant women Must use this device with caution. Please consult a doctor and obtain relevant guidance before using this equipment.
- (20) Do not fold this equipment when the power is on. Otherwise, it may affect the service life of the product and lead to other safety hazards. Do not start the equipment when it is folded.
- (21) Store the equipment as instructed in the manual for safety.
- (22) Do not get on or off this equipment when the equipment is running to prevent accidents.
- (23) Do not exceed the maximum specified user weight.
- (24) Do not expose this equipment to direct sunlight. Keep it in a cool and dry place.
- (25) Do not use the equipment in a humid environment or rain as it is not water-resistant.

- 
- (26) Do not exceed the recommended usage time. Allow the equipment to cool down for 20 minutes before restarting.
- (27) For optimal performance and stability, use the equipment on a level solid surface and ensure there are no obstructions underneath it.
- (28) Injuries to health may result from incorrect or excessive training.
- (29) Our company is not liable for any personal injuries or property losses caused by improper use of this product. We reserve the right to update, revise, or terminate the user manual and related instructions without prior notice.

## WARNING

- In an emergency, remove the safety key immediately to stop the equipment. Hold onto the handles and step on the anti-slip side strips until the equipment comes to a complete stop.
- Place the product flat on a solid level surface after unboxing. Raise and secure the upright with screws, then stand the product vertically for regular use and storage.
- The safety level of the equipment can be maintained only if it's examined regularly for damage and repaired.
- Replace defective components immediately and/or keep the equipment out of use until repair.
- Pay special attention to components that are most susceptible to wear, such as the belt and motor. These components should be inspected more frequently and replaced when necessary.
- Non-rechargeable batteries are not to be recharged.
- Rechargeable batteries are to be removed from the equipment before being charged.
- Different types of batteries or new and used batteries are not to be mixed.
- Batteries are to be inserted with the correct polarity.
- Exhausted batteries are to be removed from the equipment and safely disposed of.
- If the equipment is to be stored unused for a long period, the batteries should be removed.
- The supply terminals are not to be short-circuited.

# Contents

---

1. Product Introduction .....	4
2. Assembly.....	6
3. Operation and Adjustment .....	7
4. Care and Maintenance .....	15
5. Troubleshooting .....	16
6. Exercise Tips .....	17
7. Trademark and Legal Declaration .....	18
8. Regulatory Compliance Information .....	18

# 1. Product Introduction

Unpack the product and check the contents inside. If there is any damage or missing parts, please contact the seller.

## 01 Packing List

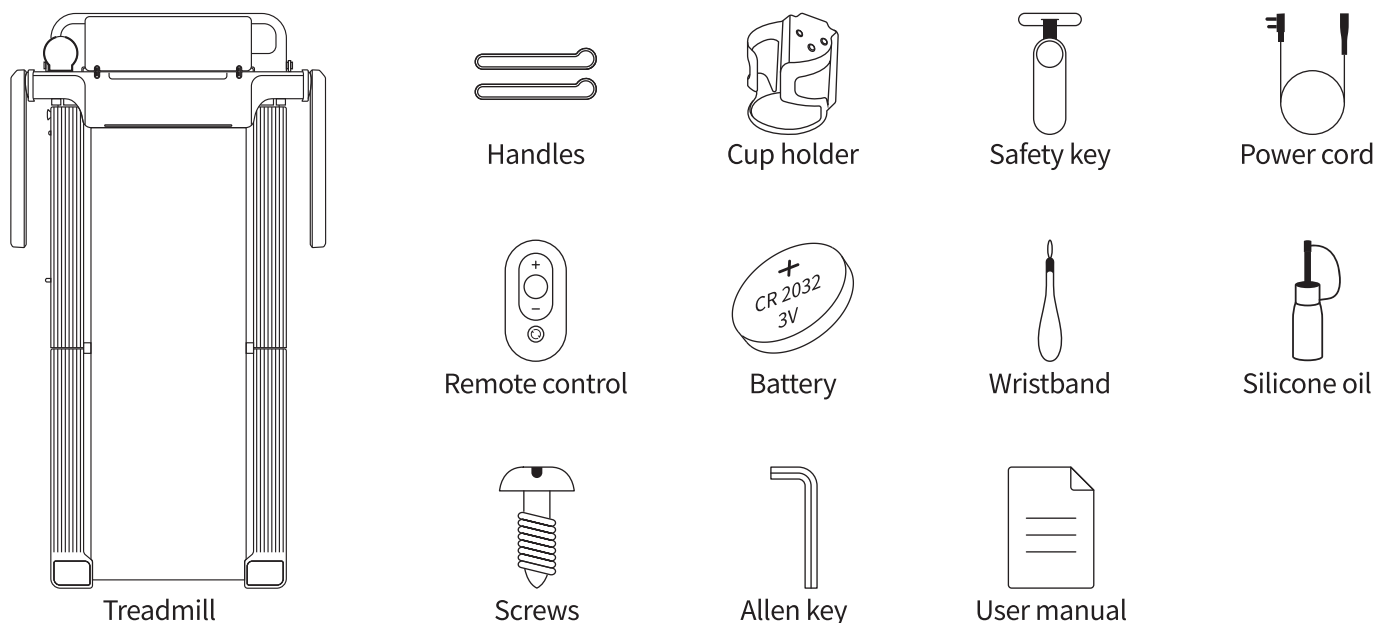

## 02 Tech Specs

Product name	: Motorized Treadmill	Unfolded size	: 1446 mm × 790 mm × 1025 mm 56.9 in × 31.1 in × 40.4 in
Model	: WP400B5	Folded size	: 286 mm × 790 mm × 1025 mm 11.2 in × 31.1 in × 40.4 in
Rated voltage	: 220-240 V~	Desktop size	: 418 mm × 275 mm 16.46 in × 10.83 in
Rated frequency	: 50/60 Hz	Desktop weight limit	: 4 kg / 8.82 lb
Rated power	: 735 W	Cup holder weight limit	: 2 kg / 4.41 lb
Speed range	: 1-10 km/h 1-6.5 mph	Class	: HC
Max user weight	: 120 kg / 264.5 lb	Age range	: 14 years and above
Net weight	: 38.4 kg / 84.66 lb		
Belt size	: 1220 mm × 410 mm 48 in × 16.1 in		

Power consumption	off mode: 0 W standby mode: 0.4W
Time to enter the Condition	standby mode: 20 min

## Radio Frequency and Radio Transmission Power

RF Specification	Working Frequency	Maximum Output Power
Bluetooth	2402-2480 MHz	8.51 dBm (EIRP)

03 Part Names

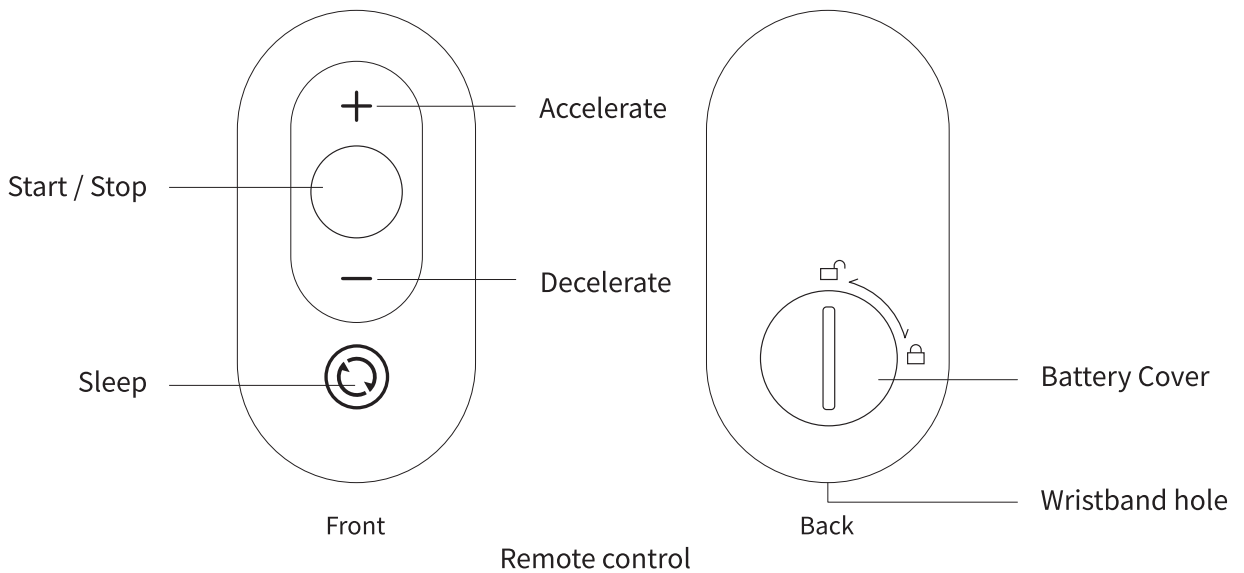
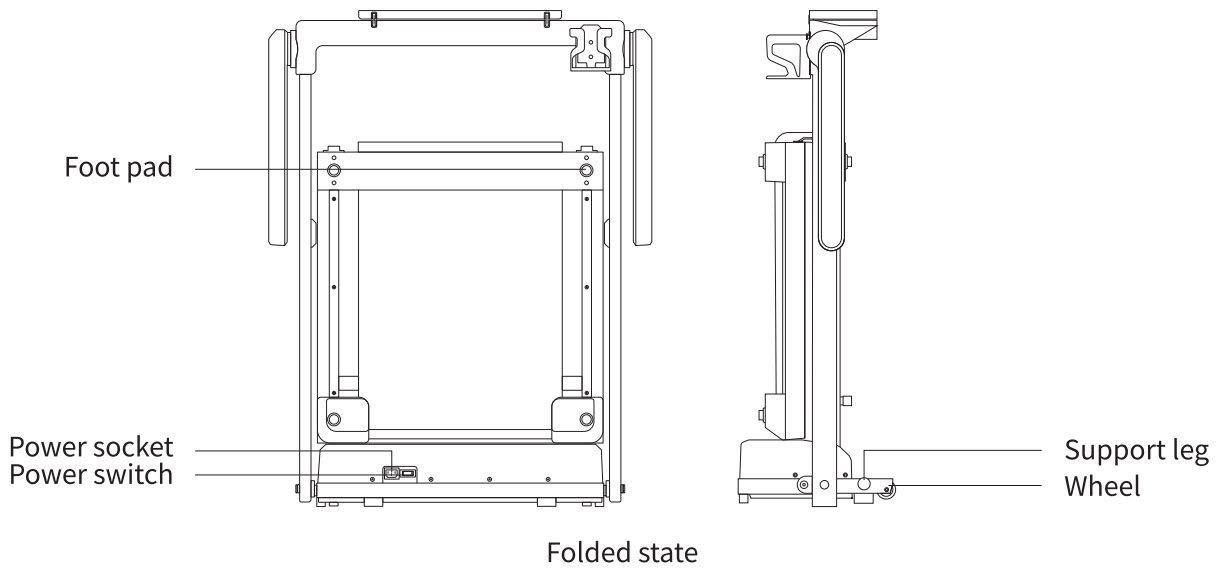
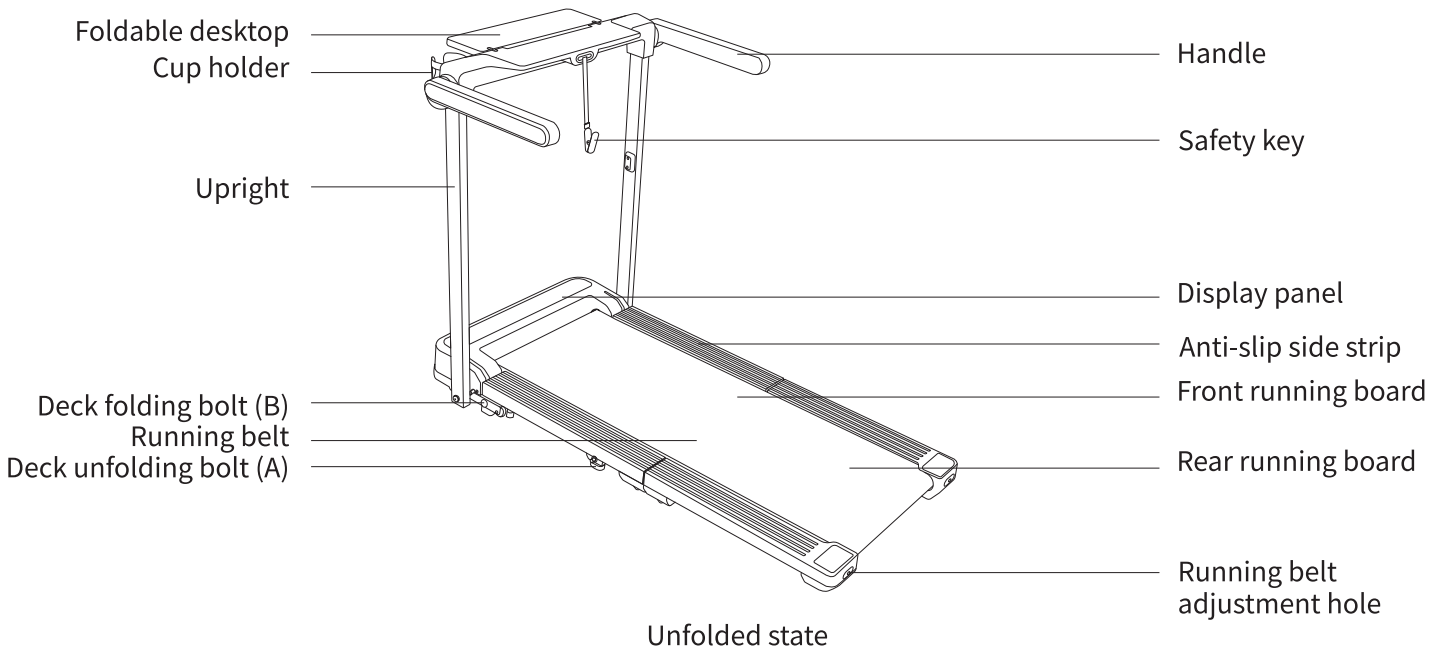

## 2. Assembly

---

### 01 Securing your upright

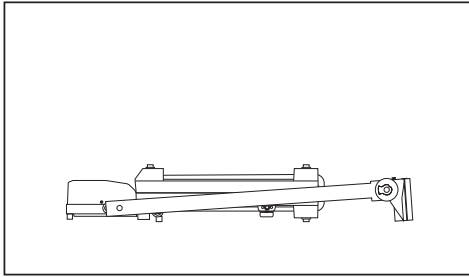

- ① After unboxing, take out the upright and the treadmill as a whole, then place it flat on a solid level surface.

Caution:

- The upright is rotatable. Please exercise caution when removing the product.
- Avoid placing the equipment on thick and soft carpet or mats.

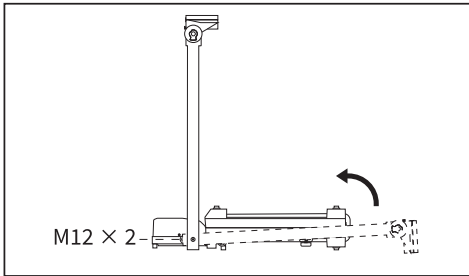

- ② Stand the upright and fasten the screws clockwise.

### 02 Installing your cup holder

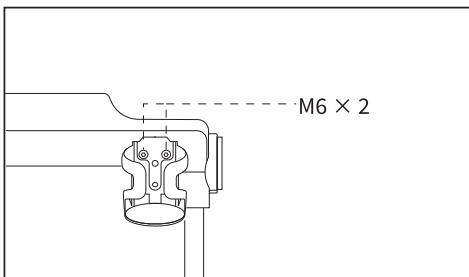

- ① Align the cup holder holes with the desktop holes, then fasten clockwise with screws.

### 03 Installing your handles

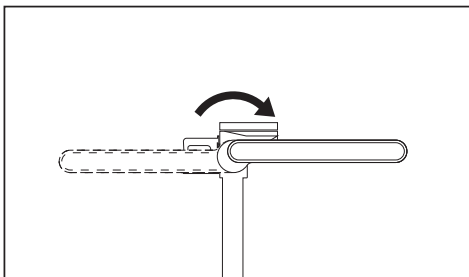

- ① Attach the handles horizontally with the scale aligned. Then rotate them 180 degrees (as shown).

# 3. Operation and Adjustment

## 01 Moving your treadmill

Before moving, please ensure the switch is turned off, the power cord is unplugged and stored, the running board is completely folded and the handles are parallel to the upright.

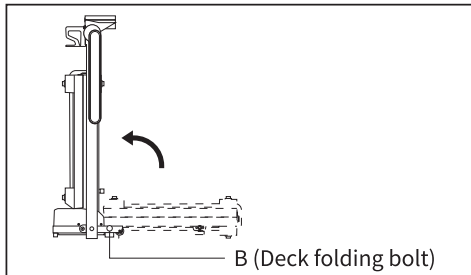

- ① While holding bolt B out, fold the deck until it locks automatically.

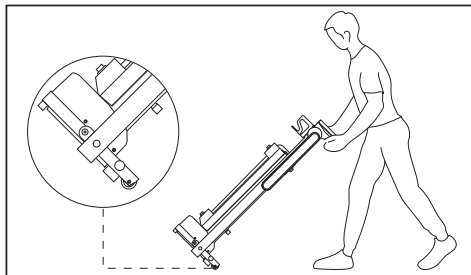

- ② Lift the equipment by the area below the desktop and move it to your desired spot.

Caution:

- Avoid touching the running belt to prevent damage or injury.
- Avoid moving the equipment on uneven floor to ensure stability.
- Maintain a proper angle between the equipment and floor to avoid friction when moving.

## 02 Unfolding your treadmill

Before unfolding the equipment, please ensure the free area behind the equipment is at least 78.7 in. × 39.4 in. (2000 mm × 1000 mm), and the free area on each side is at least 23.62 in. (600 mm).

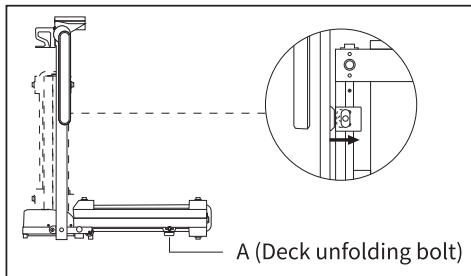

- ① While sliding bolt A right, hold the deck steady and unfold it.

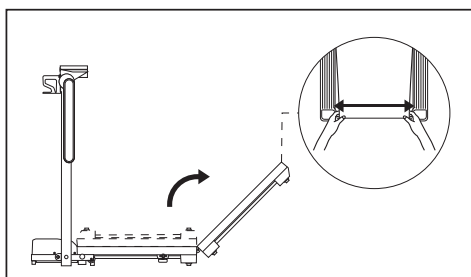

- ② Unfold the rear running board. Center the running belt by manually adjusting its front and back ends. Press down the rear running board to make it completely flat. If it is not level with the floor, rotate the foot pad for adjustment.

Caution:

- Unfold the rear running board carefully to avoid damaging the equipment and floor.
- You may hear a loud suction-like sound when unfolding the running board and feel a slight gap when stepping on the running belt. These are normal and will disappear with continued use.

### 03 Holder mode

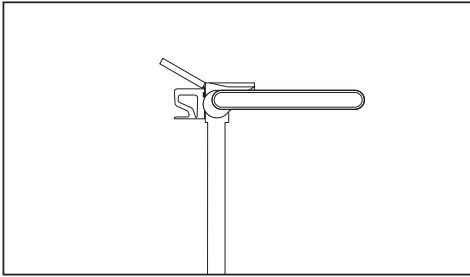

- ① Unfold and adjust the desktop between 110 and 150 degrees to use it as a holder for your phone or iPad.

**Caution:**

- Do not over-extend to prevent device slippage.
- To narrow the holder's angle within this range (150°→110°), you must first fold it to 0°, then unfold it to your desired angle.

### 04 Desktop mode

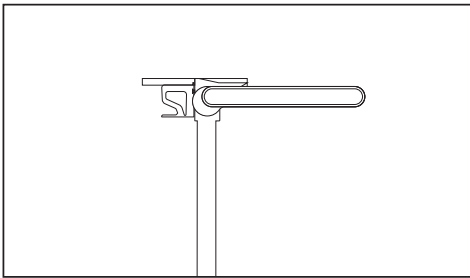

- ① Unfold the desktop to 180 degrees to use it as a holder for your laptop.

### 05 Plugging in your power cord

This product must be grounded. If a treadmill should malfunction or breakdown, grounding provides a path of least resistance for electrical current to reduce the risk of electrical shock. This product is equipped with a cord having an equipment-grounding conductor and a grounding plug. The plug must be plugged into an appropriate outlet that is properly installed and grounded in accordance with local codes and ordinances.

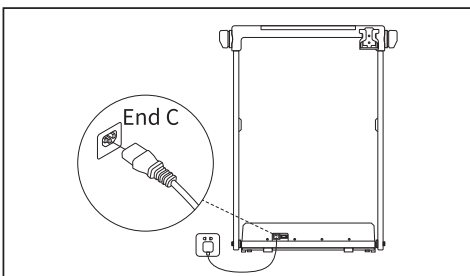

- ① Insert End C into the power socket on the product.

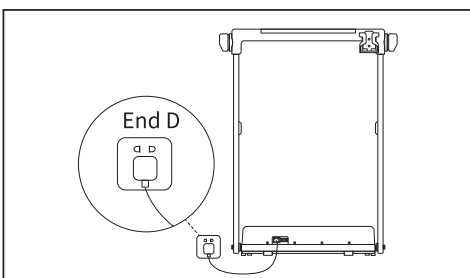

- ② Insert End D into the power outlet.

**Caution:**

- Do not modify the plug provided with the product. If the plug is not suitable for the outlet, have a qualified electrician install a suitable outlet.
- If the power cord is damaged, it must be replaced with the power cord designated by the manufacturer.

### 06 Powering on your treadmill

If the equipment is exposed to a cold environment, please let it return to room temperature before turning on the power switch. Otherwise, the equipment components may be damaged.

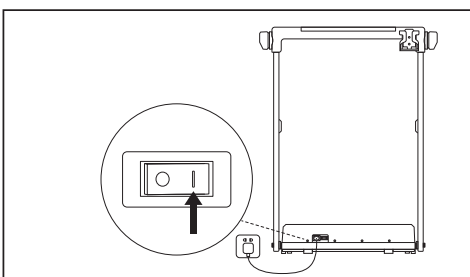

- ① Turn on the power switch until you hear a beep and see the panel lights up.

## 07 Safety key

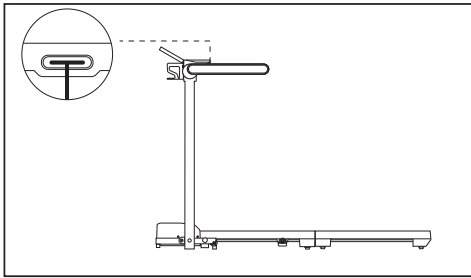

- ① Insert the safety key into the safety slot.  
Caution: The safety key must be inserted to activate the equipment.

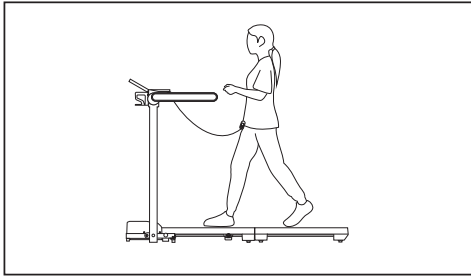

- ② Clip the lanyard of the safety key to your clothes at your waist.

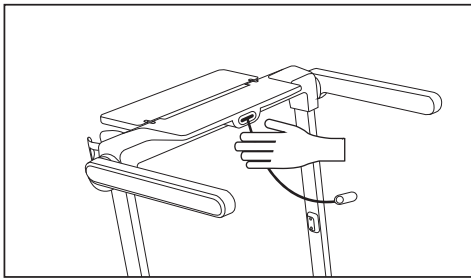

- ③ In an emergency, remove the safety key to stop the equipment. Hold onto the handles and step on the anti-slip side strips until the equipment comes to a complete stop.

**Caution:**

- Exercise caution when removing the safety key, as the equipment will stop suddenly.
- Remove the safety key when not in use, and store out of reach of children.

## 08 Remote control

### ① Battery installation

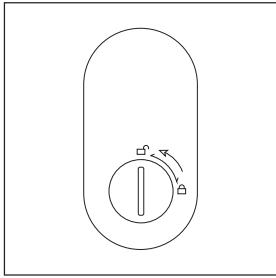

1) Unscrew the battery cover counterclockwise using an appropriate tool.

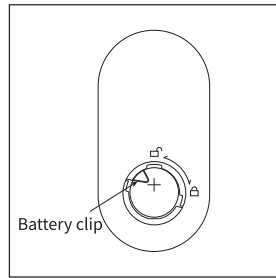

2) Align the positive and negative terminals and install a new CR2032 button battery (3V).

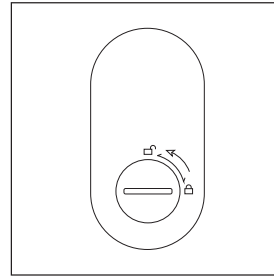

3) Close the battery cover and tighten it clockwise.

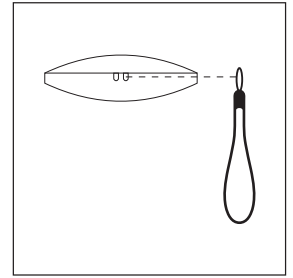

4) Thread the wristband through the hole and tighten it with a knot.

### ② Buttons and Functions

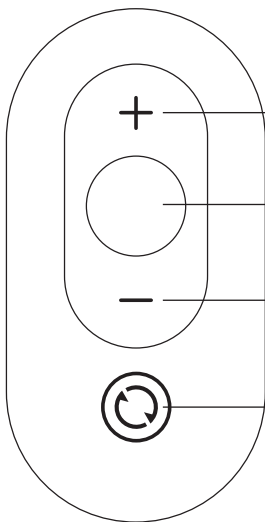

#### Accelerate

Press to increase speed by 0.5 mph increments.  
Max speed is 6.5 mph.

#### Start/Stop

Press to start.  
Press again to stop.

#### Decelerate

Press to lower speed by 0.5 mph decrements.

#### Sleep

Press and hold for 2 seconds to end workout or enter Sleep mode.

### ③ Pairing

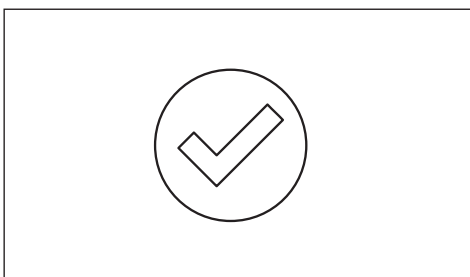

#### First-time use

The remote control and equipment are already paired and ready to use.

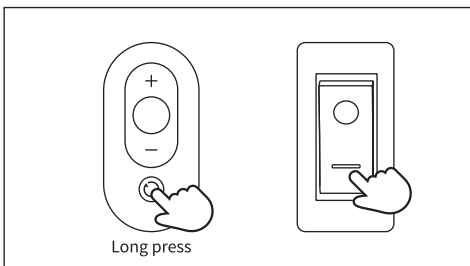

#### Switch to a new remote / Remote does not work

- Power off the equipment and wait for 10 seconds.
- Keep the remote close to the equipment.
- While holding down the Sleep button on the remote, power on the equipment, hold the Sleep button until you hear a beep.

## 09 Display panel

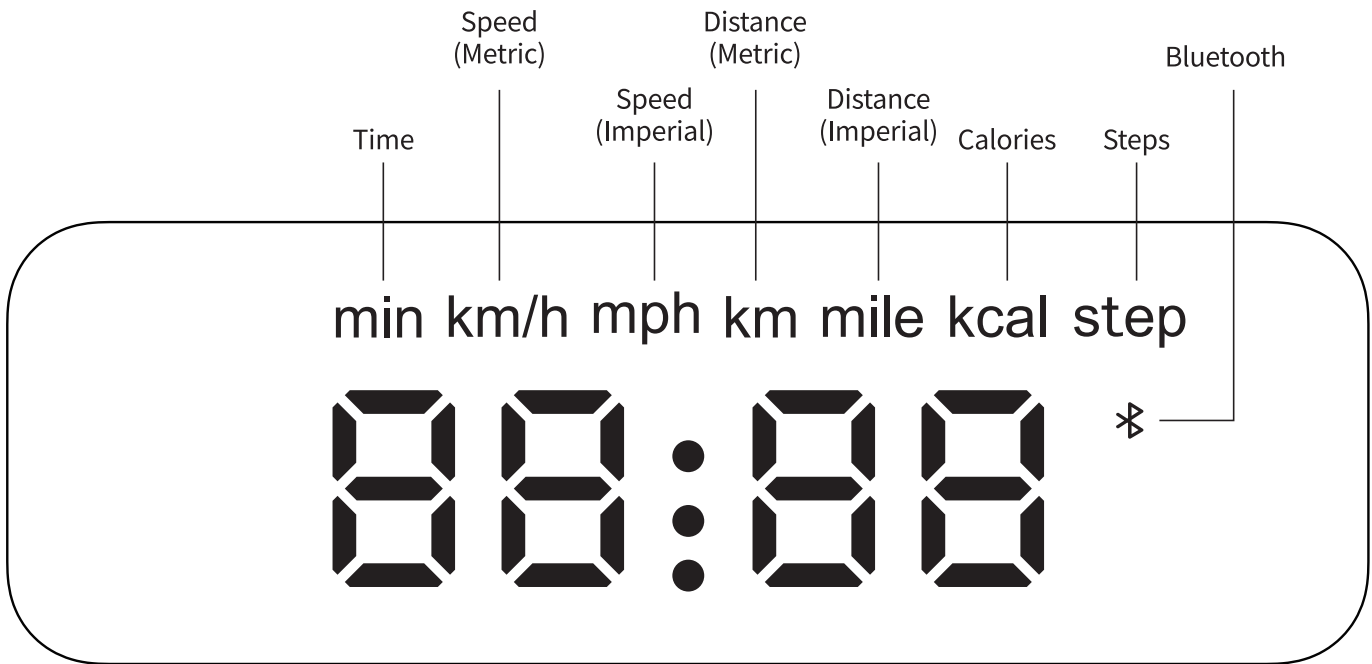

min  
23:00 \*

Workout time: 23 min

km/h  
5.0 \*

Current speed: 5 km/h

km  
3.00 \*

Distance: 3 km

kcal  
5 00 \*

Calories: 500 kcal

step  
5 00 \*

Steps: 500



**Start:** Step on the running belt and press the "Start/Stop" button on the remote control. Following a 3-second countdown, the belt will start moving at 1 mph (1 km/h).

**Caution:**

- For safety, the belt will automatically stop after 60 seconds by default when no user is on the equipment. This "No-Load Stop" feature is off by default but can be turned on in the KS Fit app (Motion > Settings).
- Make sure the safety key is inserted. Otherwise, the belt will not move.



**Speed Up/Down:** Press the "Accelerate" button to increase speed or the "Decelerate" button to reduce speed while the belt is moving.

A digital display showing the word "STOP" in a pixelated font, followed by a small asterisk.

**Pause Workout:** Press the "Start/Stop" button while the belt is moving. The belt will decelerate and the display panel will show "STOP". When the belt pauses, "STOP" disappears and the workout data is saved.

**Caution:** To resume workout, press the "Start/Stop" button again and the workout data will continue to accumulate.

A digital display showing "00:00" in a pixelated font, followed by a small asterisk.

**End Workout:** Press the "Sleep" button for 2 seconds or let the equipment idle for 10 minutes after pausing workout, the data will be reset.

**Caution:** If the app is connected, the workout data will be saved.

A digital display showing the word "SAFE" in a pixelated font.

**Sleep:** Press the "Sleep" button for 2 seconds or let the equipment idle for 10 minutes after ending workout, the display panel will turn off.

**Caution:** To wake the equipment from Sleep mode, press any button on the remote control.

A digital display showing the word "FOLD" in a pixelated font.

**Safety Key:** Without safety key inserted, the display panel will show "SAFE". Insert the safety key to clear the "SAFE" message and use the equipment.

A digital display showing the word "LOC" in a pixelated font.

**Fold:** If "FOLD" displays after stepping on the belt, inserting the safety key and starting the equipment, ensure the rear running board or uprights (if applicable) are fully unfolded until "FOLD" clears.

**Child Lock:** With child lock enabled in the KS Fit app, the equipment will not start and the display panel will show "LOC". Disable the child lock in the app to clear the "LOC" message and use the equipment.

A small asterisk symbol.

**Bluetooth:** The Bluetooth indicator flashes when the equipment is not connected to the app, and remains on when connected.

A digital display showing the word "UP" in a pixelated font.

**Upgrading:** When the firmware is upgrading, the display panel shows "UP" and the equipment cannot start. Wait until the upgrade completes and the message disappears. **Caution:** Do not power off when the equipment is upgrading.

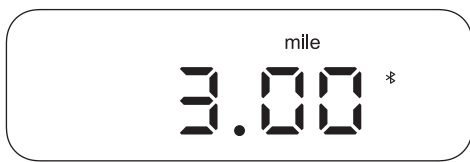

**Metric/Imperial Unit Switch:** Restart the equipment, connect the KS Fit app, tap "Me" > "Settings" > "Unit Settings", choose "Metric" or "Imperial", and restart the equipment again.

## 10 How to connect the app

Elevate your workout experience with the KS Fit app. Real-time data tracking and personalized guidance help you reach your fitness goals faster.



- ① Scan the QR code, download and install the KS Fit app.
- ② Bring your phone close to the equipment.
- ③ Turn on Bluetooth on your phone (allow it to search for nearby devices) while turning on the switch on your equipment.
- ④ Open the KS Fit app and add your equipment.

Caution:

- The equipment can only be added through the KS Fit app. If you've already connected the equipment via Bluetooth settings, please remove it and add it again using the app.
- In case pairing fails, turn off the equipment, wait for 10 seconds and repeat step ② to ④.
- For safety, avoid connecting another phone to the equipment while it is in use.

## 11 Folding your equipment

Before folding, please ensure the belt stops moving, the switch is turned off, the power cord is unplugged and stored properly.

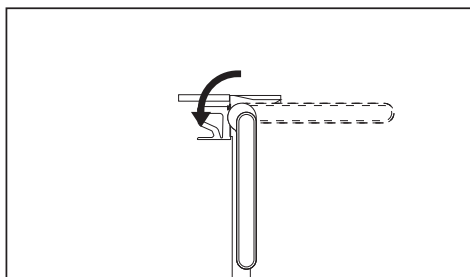

- ① Rotate the handles 270 degrees until completely parallel to the uprights.

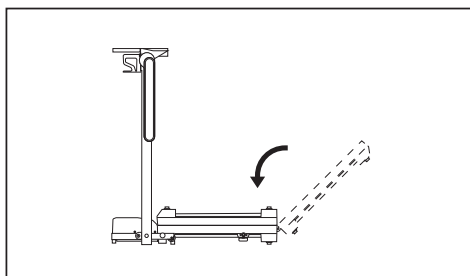

- ② Raise the rear running board until it is completely folded.

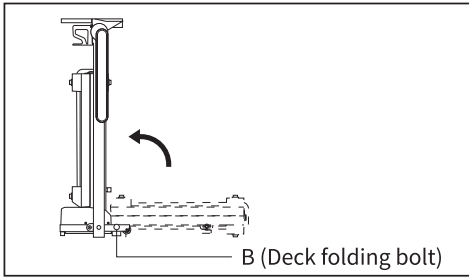

- ③ While holding bolt B out, fold the deck until it locks automatically.

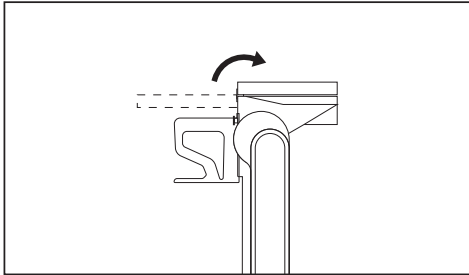

- ④ Fold the desktop.

## 12 Storing your treadmill

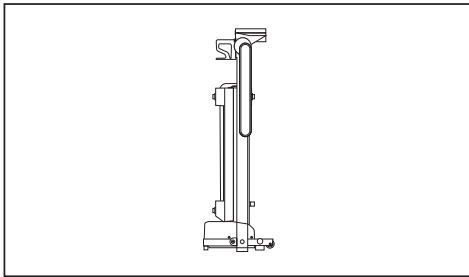

Move the equipment to your desired spot and store it upright.

Caution:

- Do not operate a folded equipment.
- Store the power cord, safety key and remote control properly for next use.

## 4. Care and Maintenance

---

For optimal performance and longevity, perform regular maintenance on your equipment from the following aspects. If you discover any damage or wear, stop using the equipment immediately and contact customer support or a qualified technician for repairs.

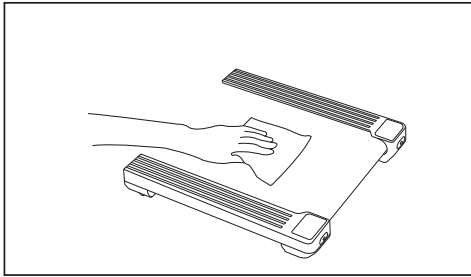

### ① Clean the equipment

- Power off the equipment and unplug the power cord.
- Add a small quantity of mild cleaner to a 100% cotton cloth, and wipe down the display panel, running belt, upright, etc.

#### Caution:

- Do not spray the cleaner directly on the display panel or running belt.
- Do not use acidic or corrosive cleaner.
- Do not wipe under the running belt.
- After a period of exercise, dust and stains may appear on the belt and on the floor behind the equipment. This is normal and can be simply wiped clean.

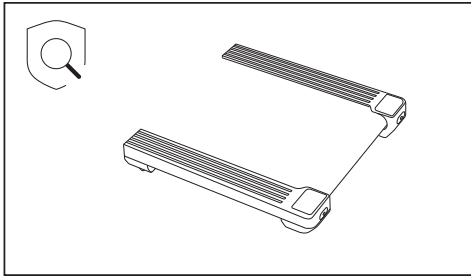

### ② Check the equipment

- Check the power cord. If any damage and wear is found, stop using it and replace the power cord immediately.
- Check the running belt. If it is not centered, too tight or too loose, adjust the running belt (→P16\_③).

Caution: If any replacement is needed, use the components designated by the manufacturer.

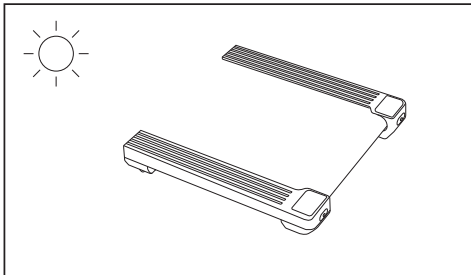

### ③ Keep cool and dry

- Keep the equipment in a cool and dry condition.

Caution: Do not use the equipment outdoors or in areas of high humidity or extreme temperature changes.

- Allow the equipment to cool down for 20 minutes after 2 hours of use.

Caution: Do not use the equipment continuously for more than 2 hours.

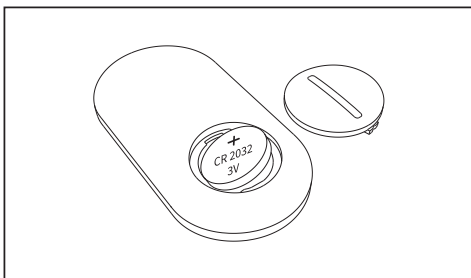

### ④ Battery replacement

- If the equipment is to be stored unused for a long period, remove the batteries.
- If the battery is depleted, remove the cover. Insert a new battery (CR2032 3V), ensuring correct +/- polarity.

## 5. Troubleshooting

Most malfunctions can be solved by the following steps. If any issues are found during use, stop using the equipment immediately and try to solve them as instructed below.

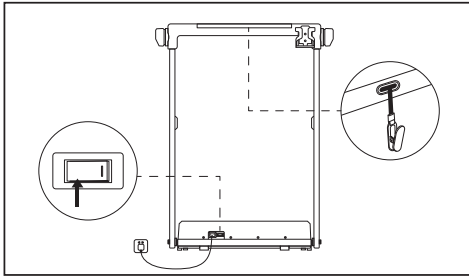

- ① Symptom: The power cannot be turned on / The power is off during use.
- Ensure both ends of the power cord are plugged in.
  - Ensure the power switch is turned on.
  - Ensure the safety key is inserted.

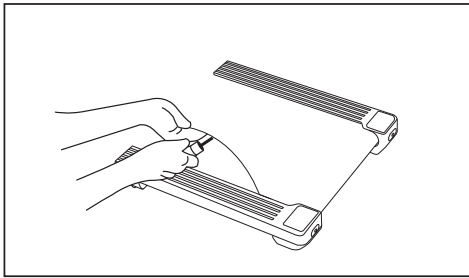

- ② Symptom: The running belt is noisy and moves unevenly
- Power off the equipment and unplug both ends of the power cord.
  - Gently raise the rear running board, raise the running belt, and apply the silicone oil in a "Z" shape at the center of the running board.
  - Power on the equipment and try again.

Caution:

- Silicone oil does not need to be applied on the entire running board as it will naturally spread during use.
- 5-10 ml of silicone oil is required for each lubrication. Excess may cause slipping.

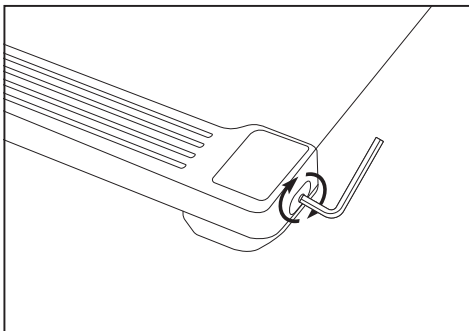

- ③ Symptom: Running belt is off center or slipping
- Note: There are two gaps on the left and right sides of the plastic shell at the front of the running belt. The running belt should be kept running in the center position. When the running belt is offset to the left or right side of the white mark on the edge, it should stop the movement and adjust the running belt to the center position.

Manual adjustment:

- Gently lift the rear running board and adjust the running belt manually (→P7\_02\_②).

Tool adjustment:

- If the running belt is still off center, adjust it with the Allen Key supplied by the following steps:

- Running belt goes to the left: turn the left adjustment hole screw clockwise by 1/4 turn.
- Running belt goes to the right: turn the right adjustment hole screw clockwise by 1/4 turn.
- Running belt is slipping: turn the left and right adjustment hole screws clockwise for 1/2 turn at the same time.

After each adjustment, run the equipment at a speed of 3-4 km/h (1.95-2.5 mph) for 1-2 minutes to verify adjustment. Repeat adjustments if needed.

Caution: If the running belt is too tight or too loose, it will affect the performance of the equipment and damage the running belt.

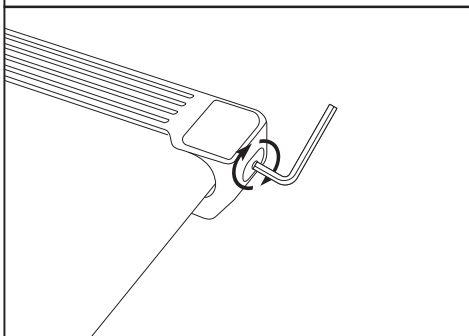

- ④ Error code description

In case of a malfunction, the display panel will show an error code as below. Turn off and restart the equipment to see if the error code disappears. If it still persists, contact the customer service for assistance. Be sure to have your product model and serial number ready which can be found on the nameplate (see the cover).

E01 Software overcurrent  
 E02 Hardware overcurrent  
 E03 IPM module overheating  
 E04 Undervoltage protection  
 E05 Overvoltage protection  
 E06 Motor phase loss protection  
 E07 Motor locked-rotor protection



E09 Motor unable to start  
 E12 Motor overcurrent protection  
 E13 Overload protection  
 E14 Hall signal missing  
 E15 Communication fault  
 E16 Module connection error

## 6. Exercise Tips

---

### 01 Exercise Intensity

Whether your goal is to burn fat or improve cardiovascular fitness, exercising at the appropriate intensity is key to achieving results. You can use your heart rate as a guide to find the right intensity level. The table shows recommended heart rate zones for fat burning and cardiovascular fitness, for reference purposes only.

165	155	145	140	130	125	115	
145	138	130	125	118	110	103	
125	120	115	110	105	95	90	
20	30	40	50	60	70	80	Age

To find the appropriate intensity level, locate your age at the bottom of the chart (rounding to the nearest ten). The lowest number is the fat-burning heart rate, the middle number is the maximum fat-burning heart rate, and the highest number is the heart rate for improving cardiovascular fitness (it is recommended to wear a heart rate monitor during exercise to ensure efficiency, which requires additional purchase).

**Burning Fat** - To effectively use fat as an energy source, you must engage in low-intensity exercise for a sustained period of time. During the first few minutes of exercise, your body will use glycogen as energy. Only after the initial few minutes of exercise does your body begin to use stored fat as energy. If your goal is to burn fat, adjust your exercise intensity until your heart rate is close to the lowest value in your training zone.

### 02 Exercise Guide

Before engaging in exercise be sure to consult your doctor.

**Warm-up:** It is recommended to warm up for 5-10 minutes before exercising, fully mobilizing joints and stretching before starting low-intensity exercise.

**Exercise:** It is recommended to exercise for 20-30 minutes, maintaining exercise intensity within the training range (during the first few weeks of training, exercise time should be kept within 20 minutes), and breathing should be kept even during exercise.

**Cool-down:** It is recommended to stretch for 5-10 minutes after exercising, which can improve joint flexibility and muscle extensibility, and prevent exercise injuries.

### 03 Exercise Frequency

To maintain or improve your physical condition, complete three training sessions per week with at least one day of rest between each session. After several months of regular exercise, if necessary, you can complete up to five sessions per week. Remember, the key to success is to make exercise a frequent and enjoyable part of your daily life.

## 7. Trademark and Legal Declaration

---

Various patents relating to the Kingsmith WalkingPad Treadmill series are developed and copyrighted by Beijing Kingsmith Technology Co., Ltd. ("Kingsmith" for short). Without the written permission of Kingsmith, any organization or individual shall not copy or distribute all or any part of this User Manual and shall not use the patents contained thereof. This User Manual, as far as possible, has included various latest function introductions and operational instructions at the time of being printed. Nevertheless, there might be discrepancies between the purchased Treadmill and those described herein due to a continuous optimization in functions and designs. Therefore, the actual Treadmill shall prevail in case of any deviations in color and appearance.

## 8. Regulatory Compliance Information

---

### WEEE Disposal and Recycling Information



All products bearing this symbol are waste electrical and electronic equipment (WEEE as in directive 2012/19/EU) which should not be mixed with unsorted household waste. Instead, you should protect human health and the environment by handing over your waste equipment to a designated collection point for the recycling of waste electrical and electronic equipment, appointed by the government or local authorities. Correct disposal and recycling will help prevent potential negative consequences to the environment and human health. Please contact the installer or local authorities for more information about the location as well as terms and conditions of such collection points.

### EU Declaration of Conformity



Hereby, Beijing Kingsmith Technology Co., Ltd. declares that the radio equipment type [WP400B5] is in compliance with Directive 2014/53/EU. The full text of the EU declaration of conformity is available at the following internet address:  
<https://de.walkingpad.com/pages/weitere-informationen>

### UKCA Declaration of Conformity



Hereby, Beijing Kingsmith Technology Co.,Ltd. declares that the radio equipment type [WP400B5] is in compliance with Radio Equipment Regulations 2017. The full text of the UKCA declaration of conformity is available at the following internet address:  
<https://uk.walkingpad.com/pages/other-information>

### UKCA PSTI Statements of Compliance

Hereby, Beijing Kingsmith Technology Co.,Ltd. declares that the radio equipment type [WP400B5] is in compliance with The Product Security and Telecommunications Infrastructure (Security Requirements for Relevant Connectable Products) Regulations 2023. The full text of the PSTI declaration of conformity is available at the following internet address: <https://uk.walkingpad.com/pages/other-information>



Manufacturer: Beijing Kingsmith Technology Co., Ltd.  
Address: Floor 4, Building 25, Area 18, ABP Park, Fengtai, Beijing, China  
MADE IN CHINA